

Service - Safety Manual

Mounting and maintenance instructions

Linear Units

LT55 and LT80 series

Code Unit _____

Serial number _____

Date _____



Linear Units LT55 - LT80 series

Table of contents

1	Safety	3
1.1	Significance of the manual instruction	3
1.2	Intended use	4
1.3	The operator's obligations	4
1.4	Operating staff	4
1.5	Modifications and alterations	5
1.6	Warranty	5
2	Assembly linear units	
2.1	Exploded view LT55-TR-S15D	6
2.2	Parts list LT55-TR-S15D	7
2.3	Exploded view and parts list LTZ55	8
2.4	Exploded view LT80-TR-S20D	9
2.5	Parts list LT80-TR-S20D	10
2.6	Exploded view and parts list LTZ80-TR-S20D	11
2.7	Toothed belt AT5 and AT10	12
2.8	Hardened Wheels	12
3	Lubrication	12
4	Alignment	13
5	Mounting	14
6	Manufacturer's declaration	15

Note: Safety signs used in the instruction manual



This symbol indicates possible danger for persons. Please follow the instructions to prevent injury.



This symbol indicates possible danger for the machine. Please follow the instructions to prevent damage to the machine.



This symbol indicates special information or

- on optimum use or
- on easier operation of the machine.

1 Safety

The Linear Unit has been constructed according to current state-of-the-art principles and valid regulations. Special attention has been given to the safety of the user. The Unit complies with the EU Machinery Directive, harmonized standards, European standards or the corresponding national standards

This is confirmed by a manufacturer's declaration.

It is forbidden to start up the linear units until it has been ensured that the machine or plant in which it has been installed complies with the regulations in the EU Machine Directive, the harmonized standards, European standards or the corresponding national standards.



Proper connections are essential to comply with the law on the electromagnetic compatibility of machine components.

Almotion only supplies the mechanical parts and never any electricity or electromagnetic parts, therefore we not accept any liability in this.

Any electrical installation must be done by a qualified EMC technician.

The following regulations apply:

- relevant accident prevention regulations
- generally accepted safety regulations
- EU Directives
- other applicable standards
- national regulations

1.1 Significance of the instruction manual

The instruction manual belongs to the designated unit and:

- must be kept readily accessible until the machine is discarded,
- must be handed over to owners or borrowers if the unit is sold or lent.

Always contact the manufacturer if there is anything that you do not understand properly in the instruction manual.



It is unavoidable that there are still a few risks for persons and property associated with these components. Therefore, every person who works with this unit and is involved with transport, installation, operation, maintenance and repair of the unit must be trained and be aware of the possible dangers. The instruction manual, in particular safety instructions, must be carefully read, understood and followed.



No knowledge or inadequate knowledge of the instruction manual voids the liability of Lineartechnik®/Almotion® for any claims. The operator is therefore recommended to have written confirmation of staff training.

1.2 Intended use

The mechanical linear drive units of **LT-series units** are designed exclusively for:

- positioning, continuously moving, conveying, palletizing, loading, unloading, clamping, tensioning, checking, measuring, handling, manipulating, and pushing work pieces or tools in industrial machines.

In general, the main uses of the **LT-series** must be taken into account.

Therefore always consult your supplier.

Any other or additional use is considered as unauthorized. The manufacturer is not liable for damages resulting from such applications. The user is solely responsible. Because of the versatility of the linear unit, the user is always responsible when the use begins

The linear units may only be used in an industrial environment as a part of a machine. The machine has to be developed according to the EG-Directives 2006/42/EG. This is to guarantee the compatibility of machines.

1.3 The operator's obligations

In accordance with EU Directive 89/655/EEC Art. 6(1) and 7 on Use of Work Equipment and EU Directive 89/391/EEC Art. 1(1) and 6(1), the operator is obliged to instruct, in particular with regard to safety, staff who are involved with assembly, operation, maintenance, repair or disassembly of a linear unit.

In accordance with EU Directive 89/655/EEC Art. 4a (Use of Work Equipment), the operator is also obliged to check the machine before initial start-up and after repairs and any malfunctioning.

1.4 Operating staff

The linear units have been constructed according to state-of-the-art principles and recognized safety regulations. Nevertheless, danger may still be associated with their use. Therefore, the machine should only be operated by competent and trained staff and only used in accordance with their intended use.

Any person involved with assembly, operation, maintenance or disassembly of a linear unit of machine must have read and understood this instruction manual, in particular Chapter 1 "Safety".

Work on conductive parts, which are never supplied by Almotion, e.g:

- installation of safety limit switches,
 - installation of a drive and testing of its direction of rotation,
- should be done by trained electricians only !**

Notes and signs for risks and danger zones

The linear units are designed to be safe. However, should there be any remaining risks for persons or property, the user must indicate these risks by the use of signs or written instructions on procedures.

Signs and adhesive labels

Keep marks, signs and adhesive labels so that they can be read in full and always follow them. Replace damaged or illegible signs and labels.

Warranty claims can only be taken in consideration if the original label with the serial number is attached on the unit.

1.5 Modifications and alterations

The linear units may not be modified neither for construction nor safety reasons without written approval of Almotion. Any unauthorized modification will void our liability. Wearing parts and spare parts may only be replaced by our service engineers themselves or after consulting our service department. The new components to be used must always be approved in writing by the manufacturer

In general, safety or protection devices may not be removed or made inactive.

If special add-on parts are used, follow the manufacturer's assembly instructions.

The following regulations apply:

- Relevant accident prevention regulations.
- Generally accepted safety regulations.
- EU Directives.
- National regulations.

1.6 Warranty

The warranty conditions are laid down in the terms and conditions of delivery and payment issued at time of the order.

Any claim for warranty is voided if :

- the machine has not be used in accordance with its intended use,
- the instructions stated in this instruction manual have not been followed,
- the unit has been modified without the manufacturer's permission,
- the screws sealed by locking varnish are unlocked.
- the original label with the serial number is not attached on the unit.





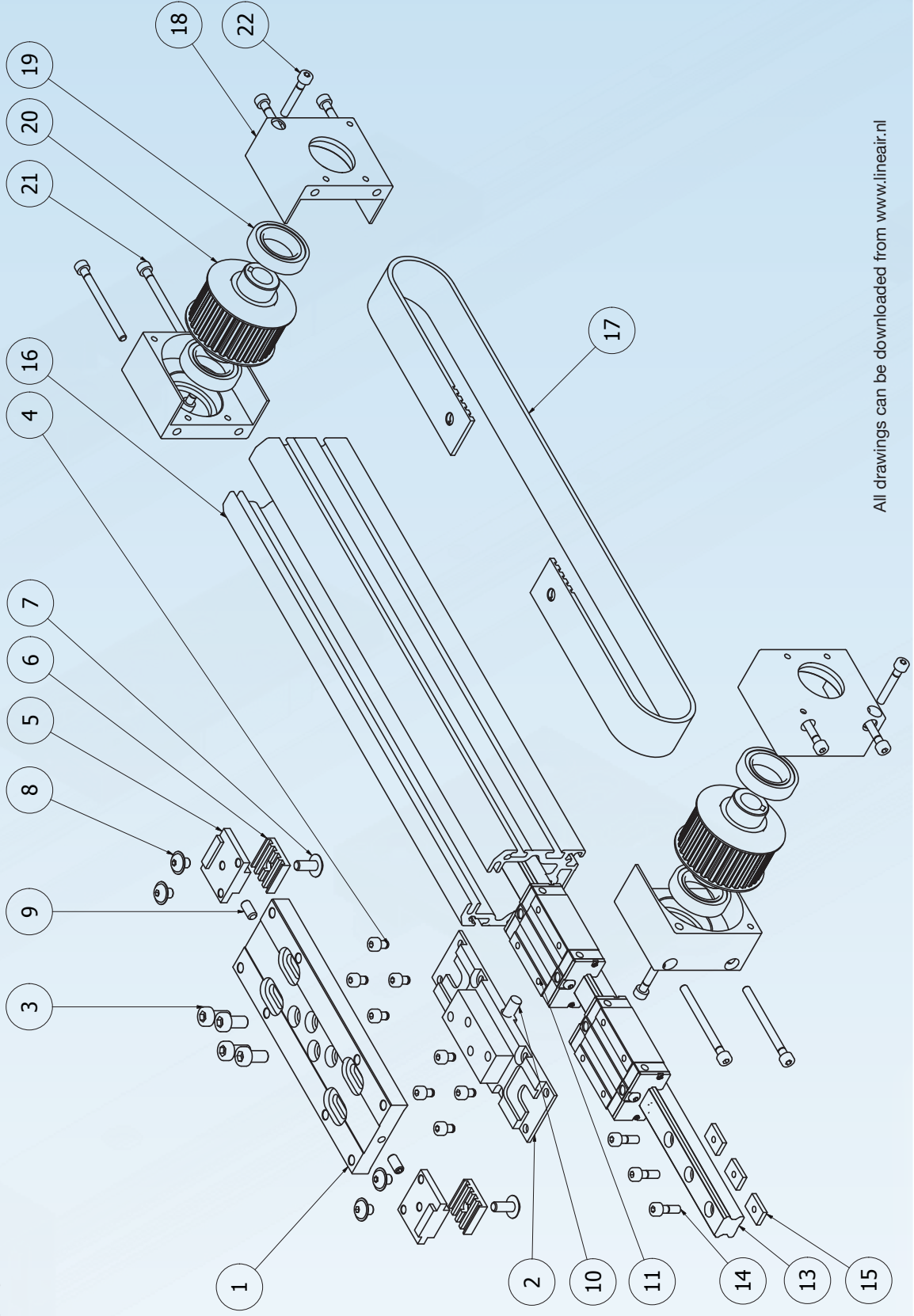







The manufacturer is only liable if original spare parts have been used for maintenance and repair work.

2.1 Assembly of the linear unit LT55-TR-S15D
Exploded view



All drawings can be downloaded from www.linear.nl

2.2 Parts list LT55-TR-S15D

Item	Part Number	Thumbnail	QTY	Description
1	55092		1	Carriage Plate
2	55094		1	Carriage Mounting Plate
3	DIN7984-6x12		4	Socket head screw with low head
4	DIN912-04x6		8	Socket head screw
5	55096		2	Belt Fix Plate
6	55095		2	Belt Clamp
7	ISO7380F-5x12		4	Button head screw with flange
8	ISO7380F-5x6		4	Button head screw with flange
9	DIN913-5x10		2	Hex screw flat tip
10	Magnet		1	Magnet
11-12	QEH-15-CA-Z0-H		2	Guide Carriage Block
13	EGR-15-U-1000-H		xxx	Guide Rail (mtr)

Item	Part Number	Thumbnail	QTY	Description
14	DIN912-04x12		10	Socket head screw
15	NUT-111-040		10	Nut
16	LT55-Profile		xxx	Alu Profile (mtr)
17	Belt 25AT5		2xstroke +465	Tooth Belt (mtr)
18	55072		4	Endcap
19	61804ZZ		4	Bearing
20	55031-AT5-30T		2	Pulley
21	DIN912-04x50		8	Socket head screw
22	DIN912-04x25		4	Socket head screw
<u>Notes</u>				

2.4 Assembly of the linear unit LT80-TR-S20D

Exploded view

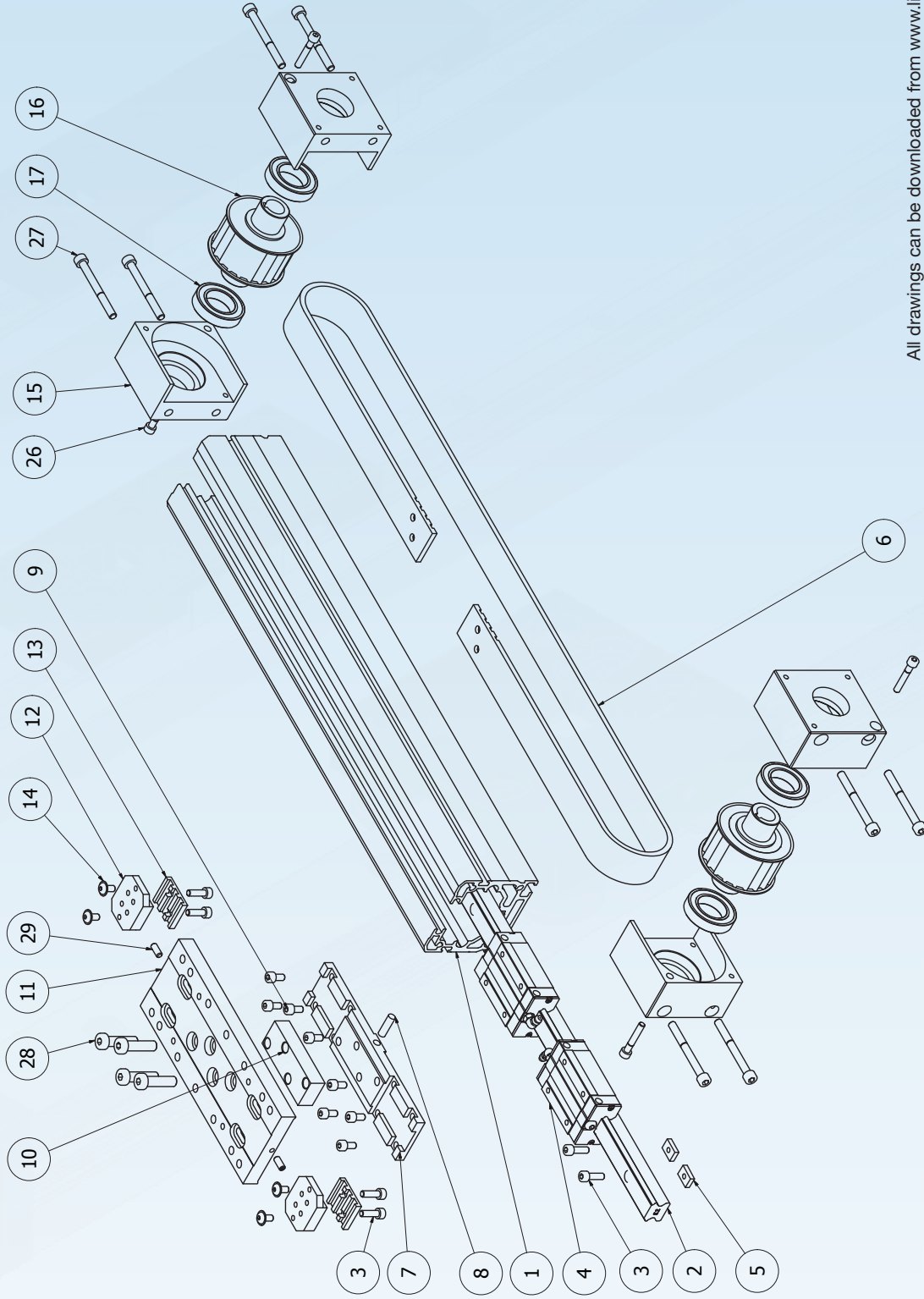

All drawings can be downloaded from www.linear.nl

2.4 Parts list LT80-TR-S20D

Item	Part Number	Thumbnail	QTY	Description
1	LT80-Profile		xxx	Alu Profile (mtr)
2	HGR-20-R-xxx-H		xxx	Rail Guide HIWIN
3	DIN912-M5x16		xxx	Socket Head screw
4	QHH-20-CA-Z0-H		2	Guide Block
5	96P0151004M5		xxx	Nut 15x10 M5
6	Belt 32 AT10		xxx	Tooth Belt (mtr)
7	80094		1	Carriage Mounting Plate
8	Magnet-6-15		2	Magnet
9	DIN912-M5x10		8	Socket Head screw
10	80093		1	Carriage Bridge
11	80092		1	Carriage Plate
12	80096		2	Belt Fix Plate

Item	Part Number	Thumbnail	QTY	Description
13	80095		2	Belt Clamp
14	ISO7380F-5x10		4	Button head screw with flange
15	80072		4	Endcap
16	80031-AT10-20T		2	Pulley
17	6905ZZ		4	Bearing
26	DIN912-05x30		4	Socket head screw
27	DIN912-06x60		8	Socket head screw
28	DIN7984-8x30		4	Socket head screw with low head
29	DIN913-5x12		2	Hex screw flat tip
<u>Notes</u>				

2.3 Assembly of the linear unit LTZ55

Exploded view and parts list

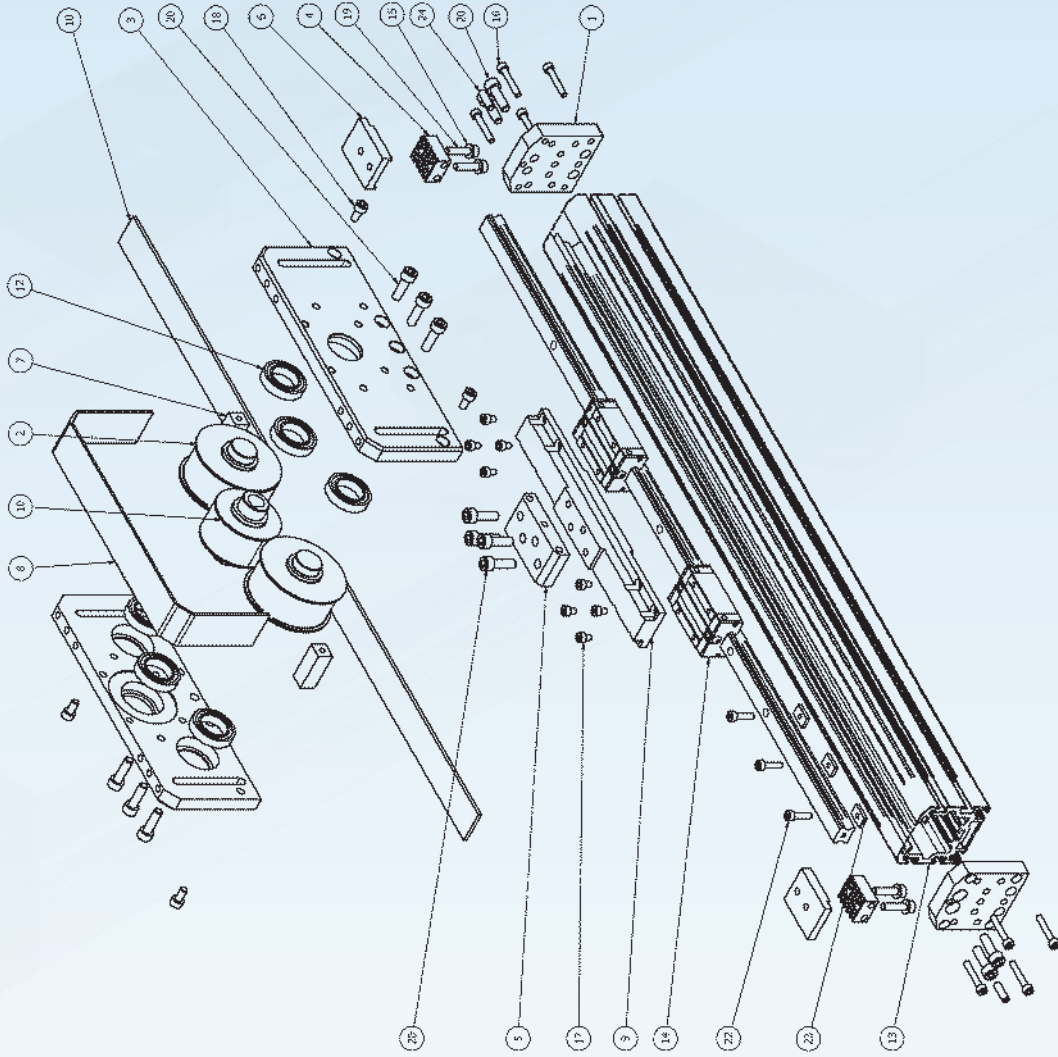

PARTS LIST				
ITEM	QTY	PART NUMBER	DESCRIPTION	Group
1	2	5507Z	End Cap	M
2	2	5508Z	Belt Guide Roll	M
3	2	5509Z	Mounting plate	M
4	2	5517Z	Cover Plate	M
5	1	5519Z	Int-Ex Block	M
6	2	5527Z	Belt Clamp	M
7	2	5529Z	Distance Block	M
8	1	5539Z	Protection Plate	M
9	1	5549Z	Internal Carriage	M
10	1	25AT5	Tooth Belt L=profile +90mm	K
11	1	55031-AT5-30T	Pulley	K
12	6	61804	Bearing	K
13	1	LT-55Z-	Alu Profile Cut to Length	K
14	1	QEH-15-600	Guide Rail with carriages	K
15	4	DIN 125 - A 5,3	Washer	
16	8	DIN 912 - M4 x 16	Cylinder Head Cap Screw	
17	8	DIN 912 - M4 x 6	Cylinder Head Cap Screw	
18	4	DIN 912 - M5 x 10	Cylinder Head Cap Screw	
19	4	DIN 912 - M5 x 20	Cylinder Head Cap Screw	
20	14	DIN 912 - M6 x 20	Cylinder Head Cap Screw	
22	XX	DIN912-04x12	Cylinder Head Cap Screw	
23	XX	Nut-111-040	14X9X2.5 M4	
24	2	DIN 913 - M5 x 16	Hex Socket Set Screw	

All drawings can be downloaded from www.linear.nl

2.6 Parts list LTZ80

Exploded view and parts list

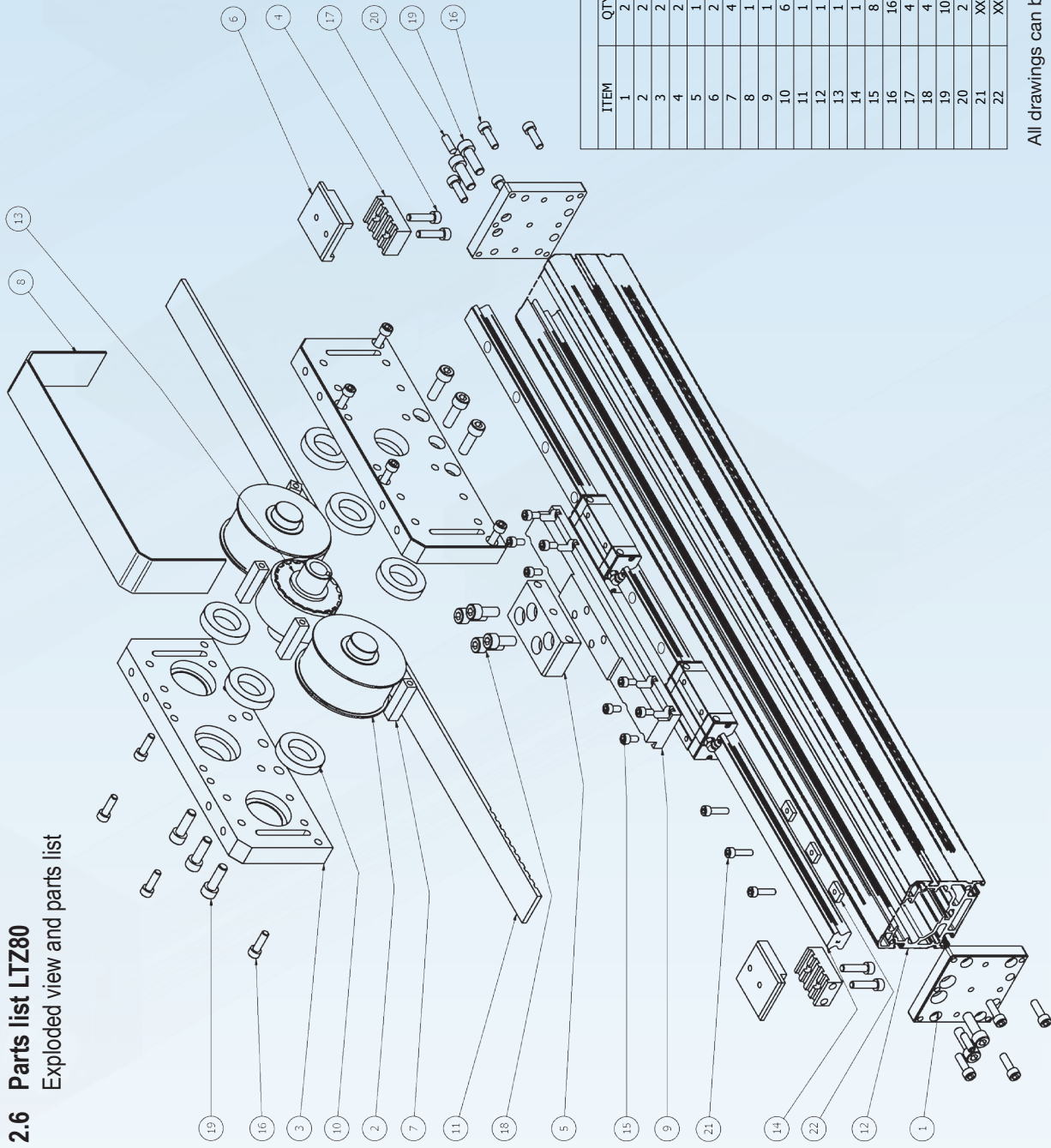

PARTS LIST			GROUP	
ITEM	QTY	PART NUMBER	DESCRIPTION	GROUP
1	2	8007Z	End cap	M
2	2	8008Z	Roll	M
3	2	8009Z	Mounting plate	M
4	2	8017Z	Cover Plate	M
5	1	8019Z	Int-Ex Block	M
6	2	8027Z	Belt Clamp	M
7	4	8029Z	Distance Block	M
8	1	8039Z	Protection Plate	M
9	1	8049Z	Internal Carriage	M
10	6	6905	Bearing	K
11	1	Belt-32AT10	Tooth Belt "E-ZUG"	K
12	1	LT80-P-750	Alu Profile	K
13	1	LTZ-Pulley-ZF	Pulley	K
14	1	QHH-20CA-750	Guide Rail with guide blocks	K
15	8	DIN 912 - M5 x 10	Cylinder Head Cap Screw	K
16	16	DIN 912 - M6 x 20	Cylinder Head Cap Screw	K
17	4	DIN 912 - M6 x 25	Cylinder Head Cap Screw	K
18	4	DIN 912 - M8 x 20	Cylinder Head Cap Screw	K
19	10	DIN 912 - M8 x 25	Cylinder Head Cap Screw	K
20	2	DIN 914 - M6 x 20	Hex Socket Set Screw	K
21	XX	DIN 912 - M5 x 20	Cylinder Head Cap Screw	K
22	XX	96P0151004M5	Nut M5 15x10x4	K

All drawings can be downloaded from www.linear.nl

2.7 Toothed belt AT5 and AT10

To make sure the toothed belt has the correct pre-tension it is advised to use a toothed belt tension gauge. For example the Contitech VSM 1 tension gauge for drive belts. If it's not available, please contact your supplier.

2.8 Hardened wheels

The hardened wheels are correctly adjusted, if you can block them with your fingers (with some effort) while pushing the carriage.
If you want more information about this, please contact your supplier.

3 Lubrication

Lubrication

During operation, occasionally check the correct function of the linear drive unit by visual inspection.

Lubrication is only required if you have a recirculating ball rail guide unit.

If you want an exact calculation of the lubrication interval, please contact your supplier.

The following factors are important for exact determination of the lubrication interval:

- Load
- Speed
- Movement
- Temperature

Short lubrication intervals are necessary in cases of:

- Effects of dust and moisture
- Heavy loading
- High speed (up to $V_{max.}$)
- Short travel



Use only Rolling bearing grease (petroleum-based polycarbamide grease)

Original grease : Fuchs Lubritec URETHYN E/M2.

About 0,5 cm³/100 km

4 Alignment

A linear actuator with an integrated guide used in a single-axis configuration only needs to meet positioning expectations. The alignment process is straight forward as the actuator works singularly bringing its load into position without any external guidance. Examples are, work-point-to-work-point or alignment-to-fixturing on the equipment.

Alignment of linear actuators in multi-axis configurations becomes more challenging as multiple actuators need to work together. Therefore, mounting must consider conditions of parallelism and perpendicularity of all joined devices for optimal performance and maximum service life.

Parallelism

There are three variables that can affect parallelism when mounting linear actuators. Answering these questions will maximize parallelism and system performance.

Carriages at the same height

Misalignment in this plane will put an unfavorable Mx-axis bending moment on the bearing system of one or both units.

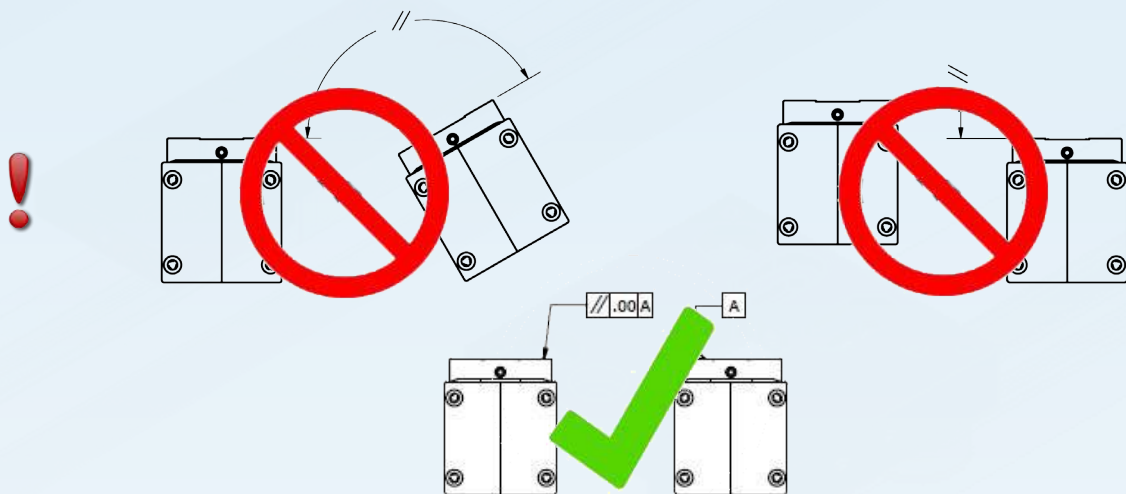

Consistent distance between the units.

Misalignment in this plane will apply an unfavorable side load.

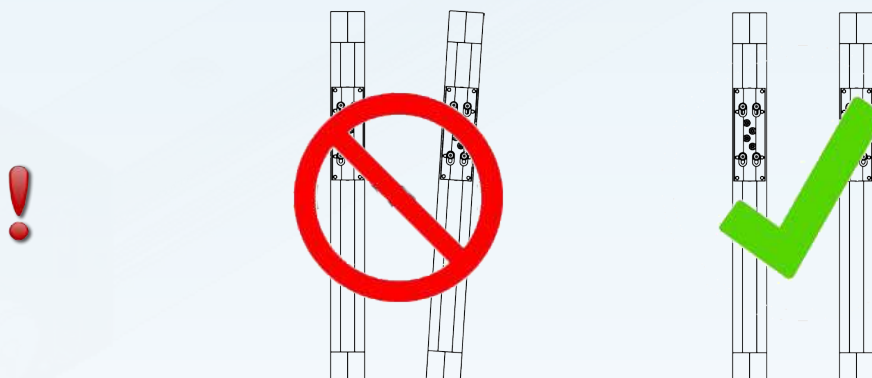

Units must be mounted level

Angular misalignment in the will apply an unfavorable bending moment in the My-axis on the bearing system of both units.

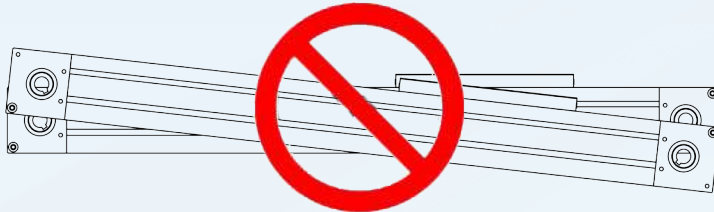

Actual tolerances related to alignment recommendations and mounting vary from actuator series. Profile ball rail systems tend to be quite rigid and alignment is more critical. Guide wheel units often have clearance, which offer some forgiveness in alignment.

When installing linear actuator mounting systems there are a number of measurement tools ranging from gauges to laser systems. Always create one axis as a reference for the X-Y and Z planes and mount the other units with respect to the reference axis. Doing so will help to get the maximum performance and longest life from your linear unit.

Conclusion

System performance and linear actuator life are affected in many ways when linear are not mounted well. Optimal system and linear actuator performance can be achieved if the actuator and guidance system are carefully mounted so the actuators are in perfect alignment.

5 Mounting of the unit

The linear unit must always be fastened on clean and level surfaces.



Our linear unit is a “partly completed machinery” as described in the European Union Machinery Directive 2006/42/EC. The linear unit cannot perform itself. The linear unit is only intended to be incorporated into or assembled with other machinery or partly completed machinery or equipment, thereby forming machinery to which this Directive applies.

6 Manufacturers Declaration

Declaration of Incorporation in accordance with the guidelines for engineering 2006/42/EG for incomplete machines.

The manufacturer: **Almotion bv**
Tielsestraat 163
6674 AB Herveld – The Netherlands

declares that the following product **LT55-LT80 series** meets the requirements of an incomplete machine according to the EC Machinery Directive 2006/42/EG.

The following basic requirements of the machinery directive 2006/42/EG according to section 1 apply: 1.1.5.; 1.3.2.; 6.1.1 .

The following harmonized standards have been applied:

DIN EN ISO 12100-1 Safety of machinery - Basic concepts, general principles for draft.

Part 1: standard concepts and methods

DIN EN ISO 12100-2 Safety of Machinery - Basic concepts, general principles for draft.

Part 2: operating instructions and specifications

Almotion commits itself to have the manual for inspection. There is also available a paper version.

Commissioning of the linear unit is prohibited until the complete machine is ready, according to the EG-Directives 2006/42/EG.

Herveld, 28-08-2009

Productmanager-Leo Peerboom



Worldwide support for
linear units.

Please contact us for your
local technical assistant.



LINEAIRTECHNIEK® by **ALMOTION**®

ISO 16016:2000

Technical product documentation - Protection notices for restricting the use of documents and products.

Almotion bv
Tielsestraat 163
6674 AB Herveld
The Netherlands
T : 0031 488 480 858
F : 0031 488 481 165
E : info@almotion.nl
I : www.lineair.nl
I : www.almotion.nl